

DP LASER



Laser Robot Applications



24-Hour Operation

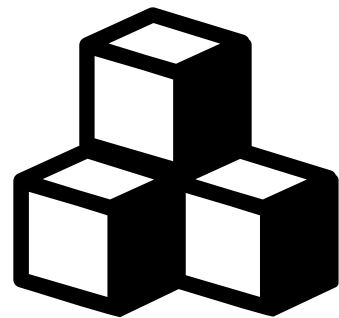

Modular Control



Batch Automation

Reputable Manufacturer, Quality Assurance

Argon Arc Welding & MIG Welding Machines

VS

Laser Welding Robot

Comparison	Argon Arc Welding & MIG	Laser Welding
Efficiency	Slow	2-5 times faster, time-saving
Result	Rough surface requires grinding	Smooth surface, minimal or no grinding required
Material Deformation	Prone to deformation	Minimal deformation
Safety	Intense light, high radiation, significant eye hazards	Low radiation, minimal eye hazards

Note: Suitable for high-volume production of stainless steel, carbon steel, galvanized steel, and aluminum alloy materials with consistent welding requirements.

Handheld Laser Welding Machine

VS

Laser Welding Robot

Comparison	Handheld Laser Welding	Laser Welding Robot
Operation	Manual	Automation, Labor-Saving
Result	Smooth surface, minimal or no grinding required	Smooth surface with minimal or no need for polishing, ensuring more stable quality
Material Deformation	Minimal deformation with contact welding	Minimal deformation, can be non-contact welding
Wire	Filler wire is needed	For small weld seams on workpieces, no need for wire feeding, saving wire costs.
Application	Small batch production, products with varying welding requirements	Large batch production, products with consistent welding requirements

Automatic Fiber Laser Welding

VS

Laser Welding Robot

Comparison	Automatic Fiber Laser Welding	Laser Welding Robot
Axis	Standard 3-axis + 2-axis	Standard 6-axis + 3-axis (expanded axis)
Flexibility	High cost and limited flexibility in coordinated motion	Can achieve welding at various angles, broader applications
Application	Expensive	Higher efficiency, more options, can weld multiple products on a single worktable

Laser Welding Robot - Parameters

Parameters	M1550-12	M1840-25	M2010-12	F10-05	F14-10
Flexibility	6-axis	6-axis	6-axis	6-axis	6-axis
Maximum Working Radius	1550mm	1840mm	2010mm	922mm	1400
Maximum Load	12kg	25kg	12kg	5kg	10kg
Repeatability	±0.05mm	±0.08mm	±0.08mm	±0.02mm	±0.05mm
Robot Weight	170kg	260kg	185kg	22kg	40kg
Control Cabinet Weight	60kg	80kg	60kg	/	/
Power	4.5kw	4.5kw	4.5kw	24V/1.5A	24V/1.5A
Temperature	0~45°C	0~45°C	0~45°C	0~45°C	0~45°C
Applicable Laser Power	1000-3000W	1000-6000W	1000-3000W	1000-3000W	1000-3000W
Material (Carbon Steel, Stainless Steel)	0.5-5mm	0.5-10mm	0.5-5mm	0.5-5mm	0.5-10mm
Applicable Material (Aluminum)	0.5-4mm	0.5-8mm	0.5-4mm	0.5-4mm	0.5-8mm

Shipping List

Categories	Serial Number	List	Description	Number
Main Units & Accessories	1	Laser System	Laser, chiller, and control system	1 set
	2	Robot System	Robot, control cabinet, teaching pendant	1 set
	3	Welding Head	CCD camera, monitor screen	1 set
	4	Wire Feeder Unit (optional)	Wire feeding components, wire drive, wire spool	1 set
	5	Protective Lenses	25*2, specific to the welding head	3PCS
	6	Copper Nozzle		1PCS
	7	Alignment Laser		1 set
	8	Blue Light Spotlight		1 set
	9	Safety Goggles		1PCS
	10	Welding Wire (optional)		1PCS
	11	Fiber Optic Cable		1PCS
	12	QBH Protective Cover	Laser-specific	1PCS
	13	Fiber Optic Welding Head Protective Cover	Welding head-specific	1PCS
	14	Gas Hose	4*6	1PCS
	15	Keys	1 key for side door and 1 key for laser	2PCS
Documents	1	Installation List	To be retained by the Quality Control Department	1PCS
	2	Certificate		1PCS
	3	Manual	Software and hardware manuals	1PCS
	4	Delivery Note	Delivery Receipt	1PCS
	5	Machine Accessories Checklist	Assembler and quality inspector are responsible for checking	1PCS

Illustration

Main Unit (Robot)			
	Robot	Control Cabinet	Teaching Pendant
	Main Unit (Laser Welding)		
Laser Welding Machine		Welding Head Monitor	Wire Feeder Control (Optional)
Consumables			
	Blue Light Spotlight	Protective Lenses	Keys

Notes:

1. Wrap all large items with protective film twice, and secure the robot with wooden brackets and screws.
2. Fragile items such as displays, screens, and lights must be wrapped in bubble wrap.
3. Motors, welding or cutting heads must be wrapped in bubble wrap.
4. Small items should be placed in paper boxes.
5. Documents should be placed in document bags.
6. During transportation, pay attention to shock absorption and verify each item according to the checklist.

Laser Welding Robot

Industrial Laser Welding Robot



Robot

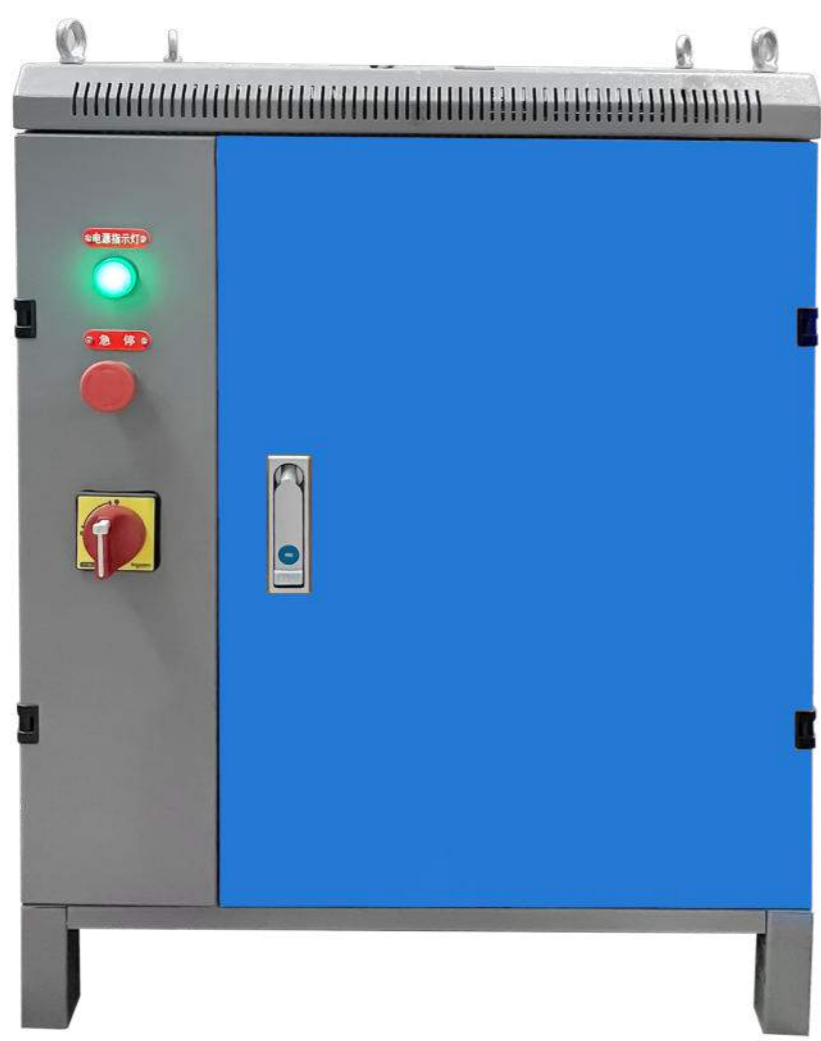

Control Cabinet



Teaching Pendant

Laser Control
Touch Screen

Laser Source
(Built-in)

Cooling System
(Built-in)



Laser Welding Robot



Collaborative Laser Welding Robot



Easy to Operate



Compact Design

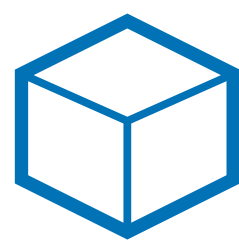

Space-Saving



Applications : Suitable for welding in industries related to sheet metal, metal cabinets, control cabinets, electrical enclosures, hardware lighting, hardware furniture, new energy vehicles, solar energy, energy storage, and more.



U-shaped Gaskets



Stainless Steel Machine Enclosures



Home Piping



Aluminum Alloy Square Boxes



Round Corner Welding



Square Welding



Round Welding



Outer Corner Welding

Laser Cutting Robot



Applications



3D Cutting of Auto Parts



Covers & Pipes



Carbon Fiber Box

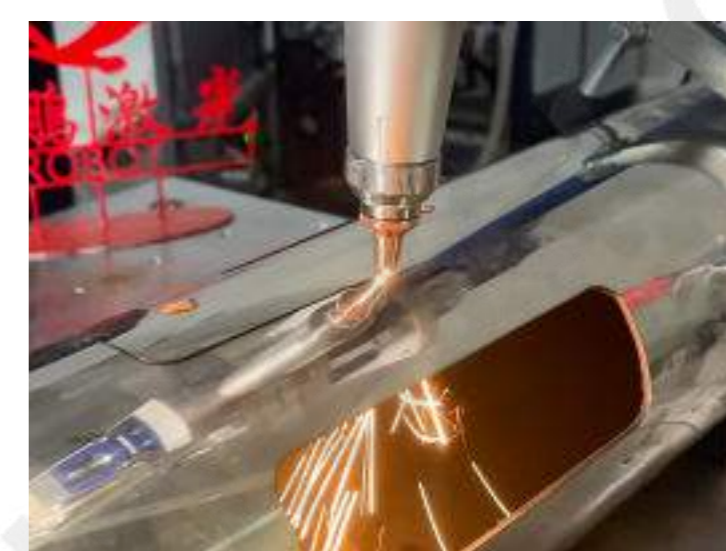

3D Cutting of Pipes

Comparison	Traditional Metal Stamping Equipment	Laser Cutting Robot
Processes	Requires shaping, punching, material dropping, edge trimming, and the use of a dedicated press machine and corresponding molds.	Once the blank is shaped, a single three-dimensional machine can independently produce the components
Cost	High press machine and mold costs, requiring different molds for various products with a new mold development cycle of 3 to 6 months	Low equipment costs, simple and quick setup, minimal preparation time, fast production speed, easy adjustments, and can be operated by a single person
Applicability	Suitable for large-scale production of single varieties	Ideal for new product development and small to medium-batch production of multiple varieties

Parameters

Parameters	M1840-25
Flexibility	6-axis
Maximum Working Radius	1840mm
Maximum Load	25kg
Repeatability	±0.08mm
Robot Weight	260kg
Control Cabinet Weight	80kg
Power	4.5kw
Temperature	0~45°C
Laser Power	1000-6000W
Material (Carbon Steel, Stainless Steel)	0.5-10mm
Applicable Material (Aluminum)	0.5-8mm

Laser Rust Removal Robot



Applications



Metal Surfaces



Pipes



Hardware
Electrical Components



Precision Parts

Parameters

Parameters	M1550-12	M1840-25	M2010-12	F10-05	F14-10
Flexibility	6-axis	6-axis	6-axis	6-axis	6-axis
Maximum Working Radius	1550mm	1840mm	2010mm	922mm	1400
Maximum Load	12kg	25kg	12kg	5kg	10kg
Repeatability	±0.05mm	±0.08mm	±0.08mm	±0.02mm	±0.05mm
Robot Weight	170kg	260kg	185kg	22kg	40kg
Control Cabinet Weight	60kg	80kg	60kg	/	/
Power	4.5kw	4.5kw	4.5kw	24V/1.5A	24V/1.5A
Temperature	0~45°C	0~45°C	0~45°C	0~45°C	0~45°C
Laser Power	1000-3000W	1000-6000W	1000-3000W	1000-3000W	1000-3000W

Laser Cleaning Robot



Applications



Tire Molds



Plastic Alloy Die Casting Molds



Weld Seam

Parameters

Parameters	M1550-12	M1840-25	M2010-12
Flexibility	6-axis	6-axis	6-axis
Maximum Working Radius	1550mm	1840mm	2010mm
Maximum Load	12kg	25kg	12kg
Repeatability	±0.05mm	±0.08mm	±0.08mm
Robot Weight	170kg	260kg	185kg
Control Cabinet Weight	60kg	80kg	60kg
Power	4.5kw	4.5kw	4.5kw
Temperature	0~45°C	0~45°C	0~45°C
Laser Power	100-300W	500W	100-300W

Single-Axis Positioner



Parameters	DP-B250-700	DP-B500700	DP-B1000-700
Load Capacity (kg)	250	500	1000
Spindle Center to Base Height (mm)	700	700	700
Positioner Cabinet Dimensions (mm)	1800*800	1800*800	1800*800
Rotation Speed (°/s)	60	60	40
Repeatability (arcmin)	±1.0	±1.0	±1.2
Rotation Angle (°)	±180	±180	±180
Eccentricity (mm)	≤150	≤150	≤100

Customization available based on customer requirements, dual-station positioner option available

Horizontal Positioner



Parameters	DP-D200-350	DP-D500-500	DP-D1000-800
Load Capacity (kg)	200	500	1000
Disk Diameter (mm)	350	500	800
Rotation Speed (°/s)	60	60	40
Repeatability (arcmin)	±1.0	±1.0	±1.0
Rotation Angle (°)	±180	±180	±180
Eccentricity (mm)	≤200	≤250	≤300
Center Distance (mm)	≤200	≤250	≤300

Customization available based on customer requirements

Linear Track

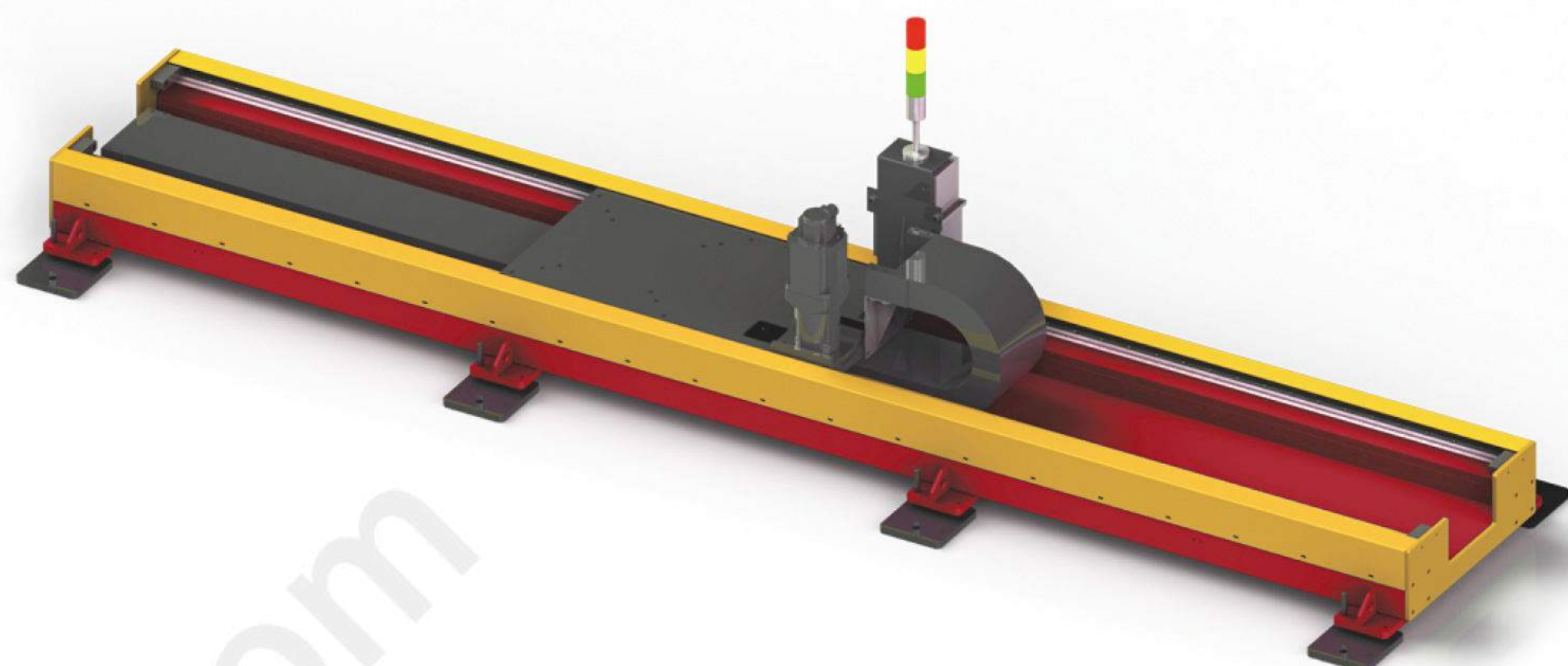

Parameters	DP-D3000-500	DP-D4000-500
Load (kg)	500	500
Total Length of Linear Track (mm)	3000	4000
Effective Travel (mm)	2300	3300
Maximum Travel Speed (m/min)	15	15
Repeatability (mm)	±0.05	±0.05

Customization available based on customer requirements

Dual-Axis Positioner

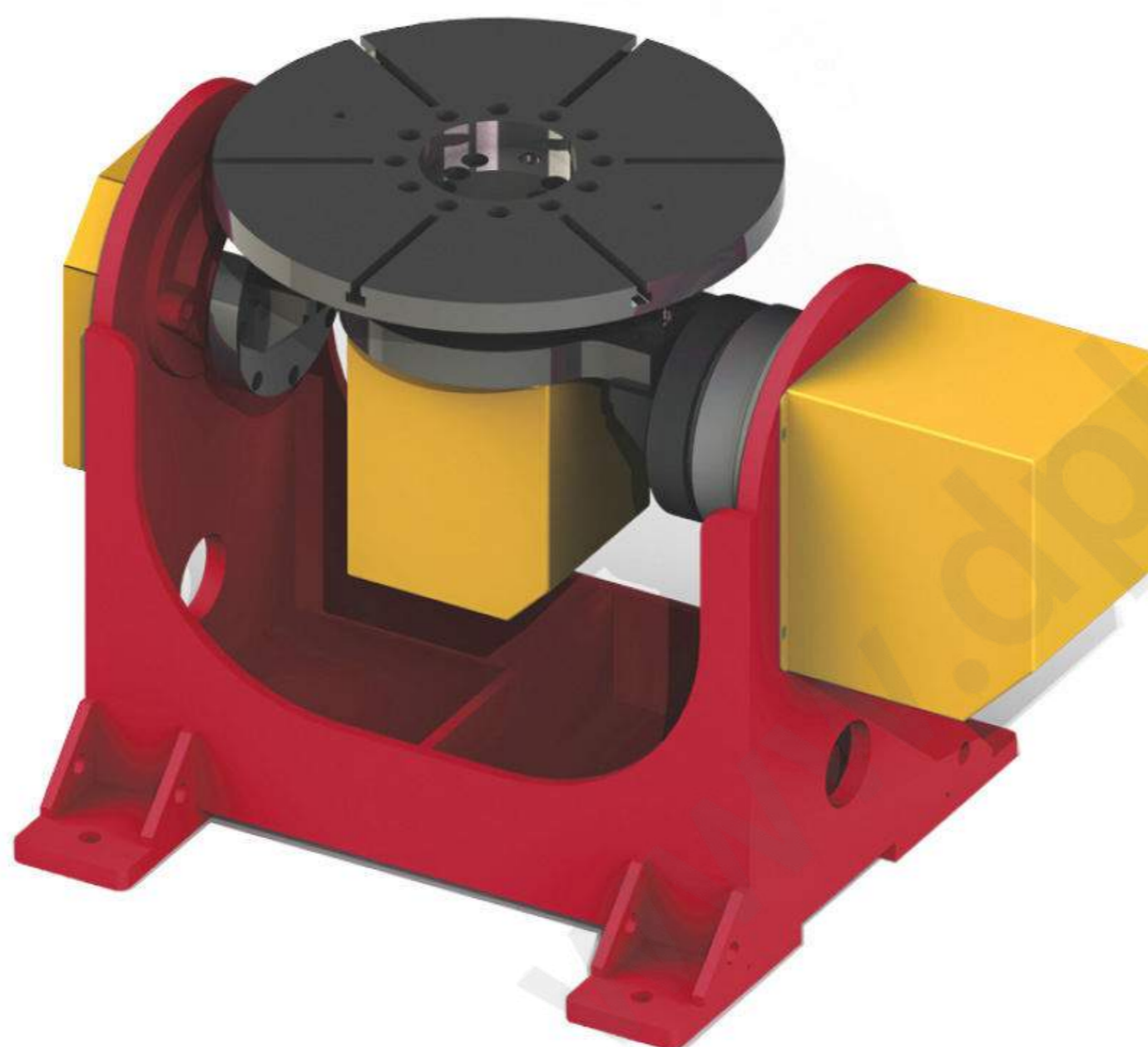

Parameters	DP-S200-400	DP-S300-500	DP-S500-600
Load Capacity (kg)	200	300	500
Disk Diameter (mm)	400	500	600
Rotation Speed (°/s)	First Axis: 80, Second Axis: 80	First Axis: 60, Second Axis: 80	First Axis: 50, Second Axis: 50
Repeatability (arcmin)	±1.0	±1.0	±1.5
Rotation Angle (°)	First Axis: ±90, Second Axis: ±360	First Axis: ±90, Second Axis: ±360	First Axis: ±90, Second Axis: ±360
Eccentricity (mm)	≤120	≤100	≤100
Center Distance (mm)	≤120	≤100	≤100

Customization available based on customer requirements

Workbench



2D Workbench



3D Workbench

Specifications	DP-T1500	DP-T2000
Hole Diameter	D16	D16
Length x Width x Height (mm)	1500*1000*750	2000*1000*750

Supporting Components



Supporting Angle Iron



U-shaped Square Box



L-shaped Square Box



Angle Meter



Angular Connecting Block

Positioning Component



Positioning Angle Ruler



Positioning Flat Ruler



Planar Angle Ruler

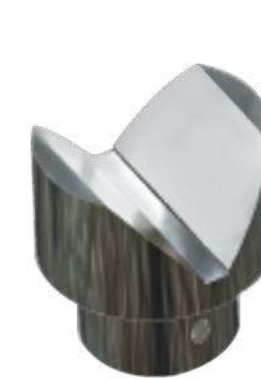

V-shaped Positioning Component

Clamping Component



With Base Quick Elbow Fixture, 45-degree Fixture



90-degree Clamping Fixture

Visual Tracking System

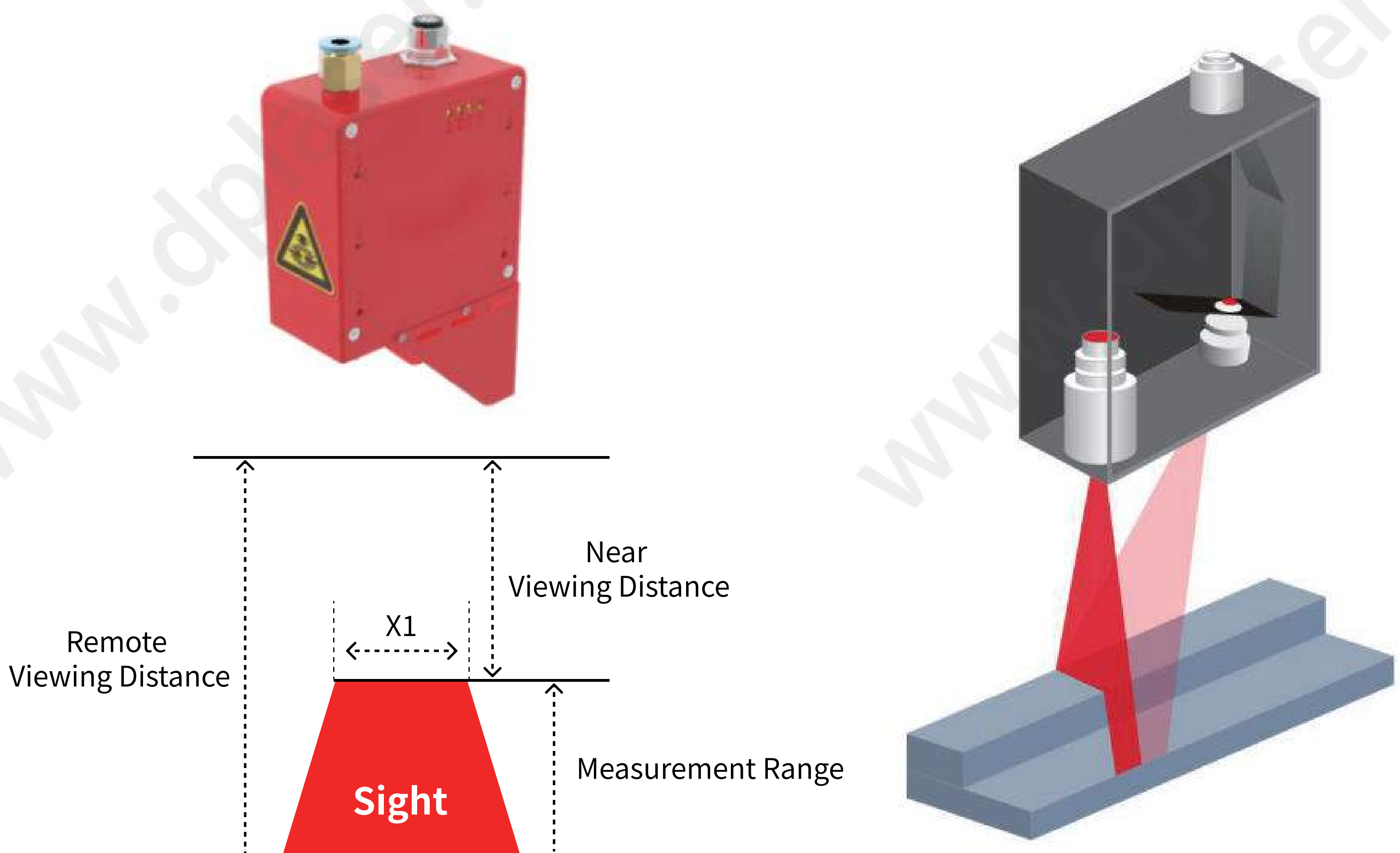

Working Principle

The laser, as the light source, emits laser beams of a specific wavelength onto the surface of the weld seam, forming a laser beam stripe. A high-definition camera positioned at another location receives this laser beam stripe and captures an image of it. Through a series of algorithmic processes, the three-dimensional feature information of the weld seam is converted into structured data within the image, including the position and shape of the object being measured. This information is then provided to guide the robot in its welding work. This robot offers high precision, non-contact capabilities, and fast operation, among other advantages.

Medium-Range Series

Model	DP-160-TD	DP-160-WD	DP-210-TD	DP-240-TD	DP-240-WD
Volume	95*68*40mm	95*68*40mm	115*74*47mm	91*73*41mm	91*73*41mm
Z-Center Observation	179mm	179mm	228mm	210mm	210mm
Z Observation Range	160~205mm	135~270mm	205~256mm	190~240mm	160~320mm
Z Up-Down Resolution	0.07~0.13mm	0.09~0.39mm	0.08~0.12mm	0.1~0.16mm	0.11~0.52mm
X Observation Width Range	40~51mm	57~110mm	36~44mm	48~64mm	65~130mm
X Up-Down Resolution	0.02~0.03mm	0.03~0.06mm	0.03~0.04mm	0.03~0.04mm	0.04~0.08mm
Detection Frequency	PP-20~40HZ、SP-10~120HZ				
Laser Power	Adjustable from 10~40mW				
Optional Models	BL/RL				
Operating Voltage	9~36V				
Power Consumption	PP-5 Watts, DP-7 Watts, SP-10 Watts				

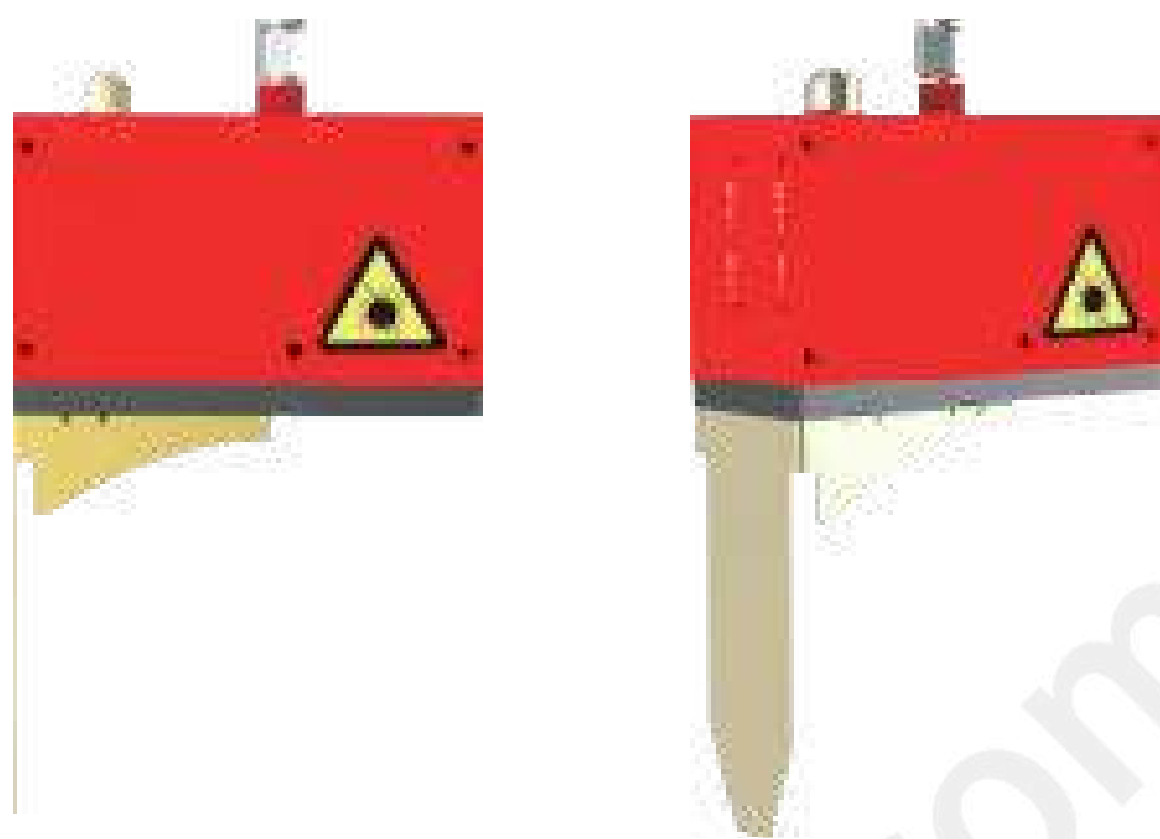

- Zero-gap series seam tracking system, designed for laser welding, TIG, plasma, friction stir welding, etc. It includes a set of vision/laser composite sensors and matching software systems
- Recognizes seams with "0" gap
- Complete standard laser seam tracking function
- Can work stably for a long time
- Can record and rehydrate the quality

Fine Docking Series

Model	DP-150-ZO-TD	DP-210-ZO-TD
Volume	115*74*47mm	115*74*47mm
Best Observation Distance	168mm	228mm
Z Observation Range	155~180mm	205~256mm
Z Up-Down Resolution	0.05~0.07mm	0.08~0.12mm
X Observation Width Range	27~31mm	36~44mm
X Up-Down Resolution	0.02~0.03mm	0.03~0.04mm
Detection Frequency	PP-20~40HZ、SP-10~120HZ	
Laser Power	Adjustable from 10~40mW	
Optional Models	BL/RL	
Operating Voltage	9~36V	
Power Consumption	PP-5 Watts, DP-7 Watts, SP-10 Watts	



About Us

Established in 2011, Shenzhen Dapeng Laser Technology Co., Ltd. is a national high-tech enterprise specializing in laser equipment research and development, manufacturing, sales, and service.

Our extensive product range includes laser cutting machines, laser welding machines, laser marking machines, laser robots, and industrial automated laser equipment. These versatile solutions cater to a wide array of industries, including electronics, IC chips, electrical appliances, lighting, jewelry, hardware tools, sanitary ware, instruments, automotive accessories, mobile phone components, molds, precision machinery, medical devices, IT electronics, metal casings, aerospace components, clothing and leather, arts and crafts, advertising decoration, models, kitchenware, and more.

DP Laser boasts a professional R&D team, ensuring the consistent and reliable quality of our products. In addition to our commitment to exceptional craftsmanship, we excel in providing efficient and effective pre-sales and after-sales services. Guided by the business philosophy of "Helping Customers Succeed, Creating Value Exemplars, and Establishing a High-end Brand in the Industrial Laser Equipment Sector," we have gained the trust and acclaim of a vast global customer base. Our equipment's total sales volume leads the industry.

To better cater to the needs of our customers, we have established a comprehensive production, sales, and after-sales support system. Our production bases are located in Shenzhen, Wenzhou, and Jiangsu, with additional large laser cutting machine production facilities in Dongguan and Jiangsu. Furthermore, we have established over 20 offices in major industrial cities and regions across China. Each office is fully equipped for equipment display, process sampling, sales, and after-sales services, ensuring the efficient and effective support our customers deserve.

We deeply understand that quality and service form the bedrock of our company's existence, while innovation drives our long-term development. Our unwavering commitment is to create value for our customers and become a trusted brand.

Shenzhen Dapeng Laser Technology Co., Ltd.

☎ Phone: +(0755) 2576 7731

🌐 Website: www.dplaser.com

📍 Address: Rm 503, Bldg 1, Nantai Yunchuanggu Park, Guangming Ave.,
Tangwei, Phoenix St., Guangming Dist., Shenzhen, Guangdong Province, China

Production Bases

Dongguan Dapeng Laser Technology Co., Ltd

Wenzhou Dapeng Laser Technology Co., Ltd

Jiangsu Dapeng Laser Technology Co., Ltd